

DEEP SEA ELECTRONICS PLC

Highfield House
Hunmanby Industrial Estate
Hunmanby, North Yorkshire
YO14 0PH England

TELEPHONE

+44 (0)1723 890099

FACSIMILE

+44 (0)1723 893303

EMAIL

sales@deepseapl.com

WEBSITE

www.deepseapl.com



Registered in England & Wales No.01319649

VAT No.316923457

DEEP SEA ELECTRONICS INC

3230 Williams Avenue
Rockford
IL 61101-2668 USA

TELEPHONE

+1 (815) 316 8706

FACSIMILE

+1 (815) 316 8708

EMAIL

sales@deepseausa.com

WEBSITE

www.deepseausa.com

YOUR LOCAL DISTRIBUTOR.

DEEP SEA ELECTRONICS PLC maintains a policy of continuous development and reserves the right to change the details shown on this data sheet without prior notice. The contents are intended for guidance only.

This data sheet is printed on 9lives 55 Silk, which is produced with 55% recycled fibre from both pre and post-consumer sources, together with 45% virgin ECF fibre.



DSECONTROL[®] MONITORING WITH INTELLIGENCE.



DSE7210 & DSE7220

AUTO START & AUTO MAINS (UTILITY) FAILURE CONTROL MODULES



The DSE7210 and DSE7220 are control modules for single gen-set applications. The modules incorporate a number of advanced features to meet the most demanding on-site applications.

The DSE7210 is an Automatic Start Control Module and the DSE7220 is an Auto Mains (Utility) Failure Control Module. The DSE7220 includes the additional capability of being able to monitor a mains (utility) supply. Both modules have been designed to start and stop diesel and gas generating sets that include electronic and non-electronic engines.

Both modules are simple to operate and feature a user friendly menu layout for improved clarity. Enhanced features include a real time clock for improved event and performance monitoring, the ability to display any language on screen and a 132 x 64 pixel LCD display.

FEATURES

- Backed up real time clock
- 132 x 64 pixel LCD display
- Configurable display languages
- USB connectivity
- Five key menu navigation
- Fully configurable via PC software
- Front panel editor
- LED and LCD alarm indication
- Engine exercise mode
- Configurable start & fuel outputs
- kWh monitoring
- Automatic load transfer
- Nine configurable inputs
- Six configurable outputs
- Configurable timers and alarms
- Magnetic pick-up
- Power save mode
- PIN protected programming
- Improved programmable event log (100) showing date and time
- Manual fuel pump control
- Manual speed control
- Alternative configuration
- Multiple date and time scheduler
- 3 Programmable Maintenance alarms
- Customisable status screens
- Low fuel level alarm delay
- Charge alternator fail warning and shutdown alarms with user programmable delay
- Sleep mode
- Load switching (Load shedding and dummy load outputs)
- Manual speed trim (on CAN engines that support this feature)
- Configurable SCADA output page
- Security levels – PC software has password system to control access to PC software features
- Fan control for additional cooling
- 'Protections Disabled' facility
- Fuel usage monitoring and low fuel alarm
- Support for up to three remote display units
- Easy access, configurable diagnostics page shows summary of output states

NEW FEATURES

- Additional programmable logic
- Additional electrical trip options
- Additional start delay functions
- Oil pressure values from additional engines
- Front panel editing of scheduler
- Displays kW as % of rated kW setting

BENEFITS

- 132 x 64 pixel ratio makes information easy to read
- Real time clock provides accurate event logging
- PC software is license free
- Set maintenance periods can be configured to maintain optimum engine performance
- Advanced PCB layout ensures high module reliability

SPECIFICATION

DC SUPPLY

CONTINUOUS VOLTAGE RATING
8V to 35V Continuous

CRANKING DIP PROTECTION
Able to survive 0V for 50mS, providing supply was at least 10V before dropout and supply recovers to 5V. This is achieved without the need for internal batteries

CHARGE FAIL/ EXCITATION
0V to 35V fixed power source 2.5W

MAXIMUM STANDBY CURRENT
160mA at 12V 80mA at 24V

MAXIMUM OPERATING CURRENT
340mA at 12V 160mA at 24V

ALTERNATOR INPUT

RANGE
15V - 333V (L-N) 50Hz - 60Hz
(Minimum 15V AC Ph-N)

ACCURACY
1% of full scale true RMS sensing

SUPPORTED TOPOLOGIES

- 3 phase 4 wire Delta
- 3 phase 4 wire
- 3 phase 3 wire
- Single phase 2 wire
- 2 phase 3 wire L1 & L2
- 2 phase 3 wire L1 & L3

MAINS/UTILITY INPUT (DSE7220 ONLY)

RANGE
15V - 333V (L-N) 50Hz - 60Hz
(Minimum 15V AC Ph-N)

ACCURACY
1% of full scale true RMS sensing

SUPPORTED TOPOLOGIES

- 3 phase 4 wire Delta
- 3 phase 4 wire
- 3 phase 3 wire
- Single phase 2 wire
- 2 phase 3 wire L1 & L2
- 2 phase 3 wire L1 & L3

CT'S

BURDEN
0.5VA

PRIMARY RATING
1A - 8000A (user selectable)

SECONDARY RATING
1A or 5A secondary (user selectable)

ACCURACY OF MEASUREMENT
1% of full load rating

RECOMMENDATIONS

Class 1 required for instrumentation
Protection class required if using for protection

SPECIFICATION

MAGNETIC PICKUP

VOLTAGE RANGE

+/- 0.5V minimum (during cranking) to 70V peak

FREQUENCY RANGE

10,000 Hz (max)

OUTPUTS

OUTPUT A (FUEL)

15 Amp DC at supply voltage

OUTPUT B (START)

15 Amp DC at supply voltage

OUTPUTS C & D

8 Amp 250V (Volt free)

AUXILIARY OUTPUTS E,F,G,H

2 Amp DC at supply voltage

DIMENSIONS

OVERALL

240mm x 181.1mm x 41.7mm
9.4" x 7.1" x 1.6"

PANEL CUT-OUT

220mm x 160mm
8.7" x 6.3"
Max panel thickness 8mm (0.3")

ENVIRONMENTAL TESTING STANDARDS

ELECTRICAL SAFETY

BS EN 60950
Safety of Information Technology Equipment, including Electrical Business Equipment

ELECTRO MAGNETIC COMPATIBILITY

BS EN 61000-6-2
EMC Generic Immunity Standard for the Industrial Environment
BS EN 61000-6-4
EMC Generic Emission Standard for the Industrial Environment

TEMPERATURE (OPERATING)

BS EN 60068
Test Ab to +70°C 60068-2-2 Hot
Test Ab to -30°C 60068-2-1 Cold

VIBRATION

BS EN 60068-2-6
Ten sweeps in each of three major axes
5Hz to 8Hz @ +/-7.5mm, 8Hz to 500Hz @ 2gn

HUMIDITY

BS 2011 part 2.1 60068-2-30
Test Cb Ob Cyclic
93% RH @ 40°C for 48 hours

SHOCK

BS EN 60068-2-27
Three shocks in each of three major axes
15gn in 11mS

DEGREES OF PROTECTION PROVIDED BY ENCLOSURES

BS EN 60529
IP65 - Front of module when installed into the control panel with the supplied sealing gasket.

OPERATION

The modules are operated via the START, STOP, AUTO and MANUAL soft touch membrane buttons on the front panel. The DSE7220 also has a TEST button. Both modules include load switch buttons. The main menu system is accessed using the five navigation buttons to the left of the LCD display.

CONFIGURATION

The modules can be configured using the front panel buttons and by using the DSE Configuration Suite PC software and a USB lead.

INPUTS & OUTPUTS

Analogue inputs are provided for oil pressure, coolant temperature and fuel level. These connect to conventional engine mounted resistive sensor units to provide accurate monitoring and protection facilities. They can also be configured to interface with digital switch type inputs for low oil pressure and high coolant temperature shutdowns. Six user configurable digital inputs are also included.

Outputs are provided for fuel solenoid, start solenoid and six additional configurable outputs. On these configurable outputs a range of different functions, conditions or alarms can be selected.

INSTRUMENTATION

The modules provide advanced metering facilities, displaying the information on the LCD display. The information can be accessed using five menu navigation buttons to the left of the display.

DSE7210	DSE7220
Generator Volts L1-N, L2-N, L3-N	Generator Volts L1-N, L2-N, L3-N
Generator Volts L1-L2, L2-L3, L3-L1	Generator Volts L1-L2, L2-L3, L3-L1
Generator Amps L1,L2,L3	Generator Amps L1,L2,L3
Generator Frequency Hz	Generator Frequency Hz
Engine Speed RPM	Engine Speed RPM
Engine Oil Pressure	Engine Oil Pressure
Fuel Level %	Fuel Level %
Engine Temperature	Engine Temperature
Plant Battery Volts	Plant Battery Volts
Engine Hours Run	Engine Hours Run
Generator kVA	Generator kVA
Generator kW	Generator kW
Generator Power Factor	Generator Power Factor
Charge Alternator Voltage	Mains Volts L1-N, L2-N, L3-N
Generator kVAh	Mains Volts L1-L2, L2-L3, L3-L1
Generator kWh, kVAh, kVAh	Mains Frequency Hz
Number of engine starts	Generator Power Factor
	Charge Alternator Voltage
	Generator kVAh
	Generator kWh, kVAh, kVAh
	Number of engine starts

EXTENDED INSTRUMENTATION FROM ELECTRONIC ENGINES (WHERE AVAILABLE)

Oil temperature	Oil temperature
Coolant pressure	Coolant pressure
Turbo pressure	Turbo pressure
Inlet manifold temperature	Inlet manifold temperature
Exhaust temperature	Exhaust temperature
Fuel Consumption	Fuel Consumption
Atmospheric pressure	Atmospheric pressure
Fuel temperature	Fuel temperature
Fuel used	Fuel used

EVENT LOG

The modules include a comprehensive event log that shows the most recent 100 alarm conditions. This feature is enhanced by the real time clock, as it allows each alarm condition to be stamped with the date and time. The event log displays the fault condition, time and date all on one page.

ELECTRONIC ENGINE COMPATABILITY

- CAT
- Cummins
- Deutz
- John Deere
- MTU
- Perkins
- Scania
- Volvo
- IVECO
- Generic
- Plus additional manufacturers

RELATED MATERIALS

TITLE	PART NO'S
DSE7xxx Manual	057-074
DSE72xx/73xx	
PC Software Manual	057-077

DSE7210 & 7220

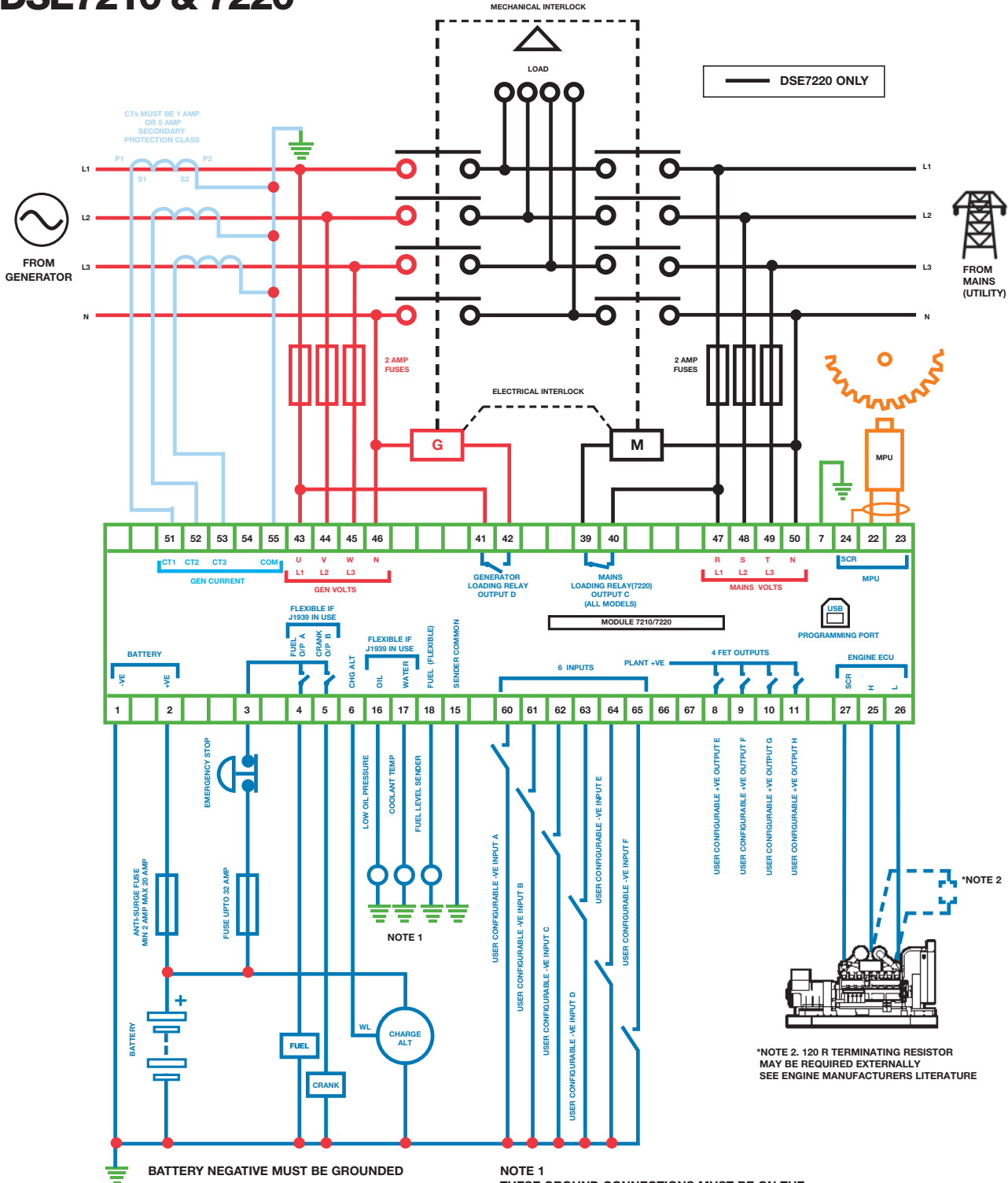

BATTERY NEGATIVE MUST BE GROUNDED

TERMINALS SUITABLE FOR 22-16 AWG (0.6mm - 1.3mm) FIELD WIRING

TIGHTENING TORQUE = 0.8Nm (7lb-in)

NOTE 1
 THESE GROUND CONNECTIONS MUST BE ON THE ENGINE BLOCK, AND MUST BE TO THE SENDER BODIES. THE GROUND WIRE TO TERMINAL 15 MUST NOT BE USED TO PROVIDE A GROUND CONNECTION TO ANY OTHER DEVICE

***NOTE 2**
 *NOTE 2. 120 R TERMINATING RESISTOR MAY BE REQUIRED EXTERNALLY SEE ENGINE MANUFACTURERS LITERATURE